



**Diversity Mini  
Wireless System**  
for Vocalist and Music Instruments

# ***Table of Contents***

---

<b>System Components.....</b>	<b>1</b>
<b>Receiver Features.....</b>	<b>2</b>
<b>Transmitter Features.....</b>	<b>4</b>
<b>System Setup.....</b>	<b>9</b>
<b>Specifications.....</b>	<b>11</b>

Thank you for choosing our wireless system, In order to obtain the best efficiency from the system, you are recommended to read this instruction manual carefully.

# ***System Components***

---

## **All systems include**

Antenna diversity receiver  
6.35mm audio cable  
Power supply  
User guide

## **Body-pack systems include**

Body-pack transmitter  
Microphone choice:  
Lavalier/Tie-clip  
Headset  
Guitar cable  
Wired instrument microphones  
(saxophone, violin, viola, cello,  
acoustic guitar etc)

## **Musical instrument systems include**

Guitar transmitter (for Fender or Gibson)  
Saxophone, Trumpet, Flugel transmitter  
Violin, Viola, Acoustic guitar and Mandolin  
transmitter

## **System Features**

UHF 600-952MHz frequency range (region dependant)  
Antenna diversity for maximum range and dropout protection  
PLL Synthesized circuit  
Pre-set 100 (10\*10) selectable frequencies (bandwidth dependant)  
IR sync downloading the frequency from receiver  
LCD display shows status of frequency, AF and RF signal etc  
Receiver powered by DC 9V or 2\*1.5V AA battery  
Up to 300 feet(100m) line-of-sight operating range  
Designed for vocalist and musical instrument applications

# Receiver Features

## Front/Top Panel

### 1. Power switch

Tap to turn on, tap to turn off

### 2. LCD display

The 63mm\*22mm high resolution LCD display shows the group, channel, frequency, antenna status, AF & RF level and Battery life.

### 3. IR (Infrared) port

Send IR signal to transmitter for synchronization

### 4. UP button

Adjust the frequency, channel, group incrementally

### 5. SET button

Menu control to set group, channel, frequency, IR Synchron.

### 6. DOWN button

Adjust the frequency, channel, group degressively

### 7. Volume control

Adjust the volume level

### 8. IR button

Tap to send IR signals from receiver

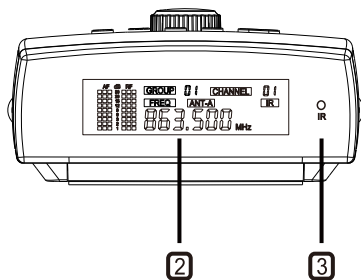
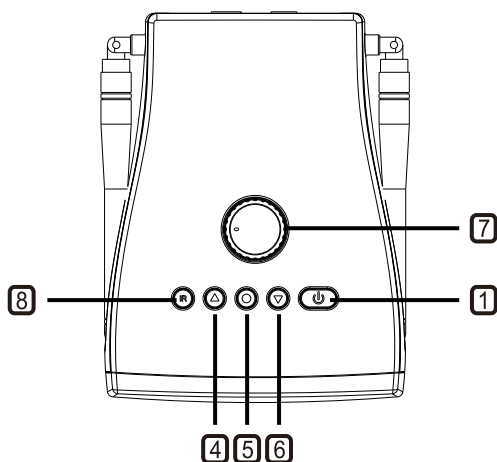

# Receiver Features

---

## Side/Bottom/Back Panel

- 8. Power supply jack (DC9V / 200mA)  
Connecting the power supply unit
- 9. Balanced XLR output jack  
Connect the unbalanced input, e.g. of  
mixer or amplifier
- 10. Antennas
- 11. Battery compartment

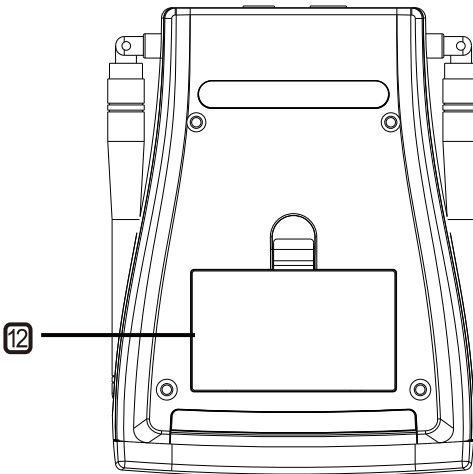
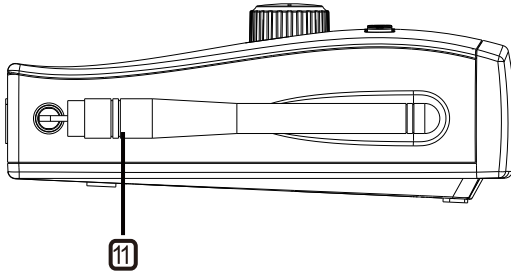
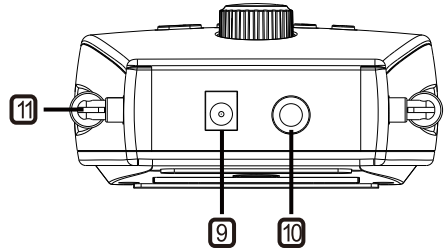

# Transmitter Features

## Body-pack Transmitter

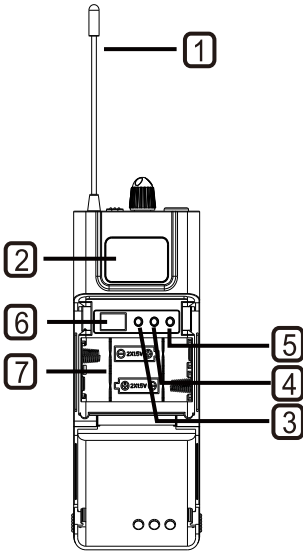

1. Antenna  
1/4 wave length wire type antenna, it should be fully extended during normal operations
2. Backlit LCD  
Display frequency and battery life, if the battery symbol blinks, the battery need to be replaced immediately
3. UP button  
Adjust the frequency, incrementally
4. SET button  
Menu control to set frequency
5. DOWN button  
Adjust the frequency degressively
6. IR infrared port  
Receiver infrared beam to synchronize frequencies, hold the transmitter with its IR port facing direct to receiver's IR port in a distance between 5-20cm.  
**Note:** When using multiple systems, only one transmitter IR port should be expose at a time.
7. Battery compartment  
To replace batteries, slightly press the marked positions on left and right side of the cover and open forward, make sure to put the battery in the right polar directions.

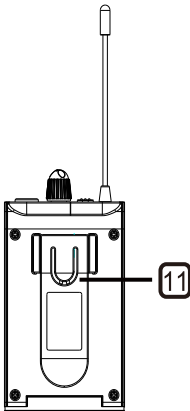

8. Input  
3-pin mini XLR input for supplier microphone, guitar cable or other musical instrument microphones (saxophone, violin, viola, cello, acoustic guitar etc)
9. Volume control  
Clockwise to enlarge, counter-clockwise to reduce
10. Light touch power switch  
Tap to turn on, long press (2 seconds) to turn off.
11. Belt-clip  
Clip to the belt or guitar strap

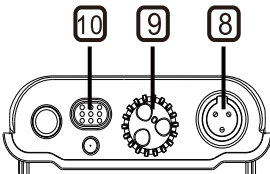

# Transmitter Features

## Musical Instrument Transmitter

### Guitar Straight plug/Angled plug

#### 1. 1/4" inch plug

Insert this standard 1/4" plug into your electric musical instrument. Note that the angling of the plug can be configured for Fender and Gibson electric guitar and bass. The angled plug can be configured for all 6.35mm end mount-jacks electric musical instrument e.g. electric violin, electric saxophone etc.

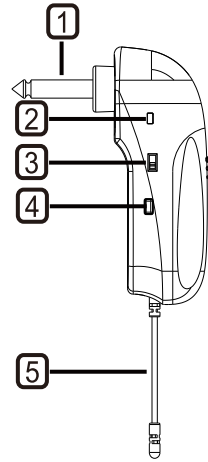

#### 2. BATT/PO

Power and battery LED, this blue LED remains lighting as long as the transmitter has power; the blue LED flashing means the battery need to be replaced immediately.

#### 3. Mute

Move the switch in the direction of the arrow to mute the microphone

#### 4. Light touch power switch

Tap to turn on, long press (2 seconds) to turn off.

#### 5. Antenna

1/4 wave length wire type antenna, it should be fully extended during normal operations

#### 6. IR infrared port

Receiver infrared beam to synchronize frequencies, hold the transmitter with its IR port facing direct to receiver's IR port in a distance between 5-20cm.

#### 7. Battery compartment

Insert a standard AA alkaline battery here, make sure to put the battery in the right polar directions.

#### 8. Battery cover

Pull back gently on this cover at the ribbing and pry upwards to remove

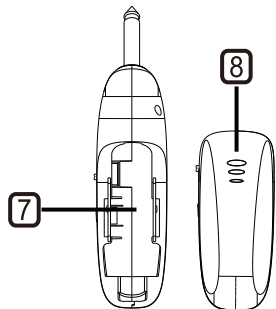
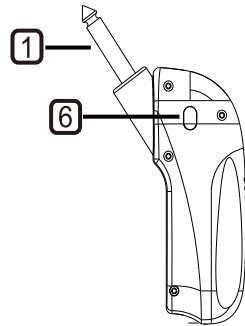

# Transmitter Features

## Saxophone/Horn Transmitter

### 1. Input mic

Unidirectional Condenser microphone pick up of Saxophone / horn's sound

### 2. Gooseneck pipe

Adjustable at any Angle

### 3. Mounting Screw

To secure the transmitter onto the bell of saxophone / horn, rubber protection avoids damage of the instrument.

### 4. BATT/PO

Power and battery LED, this blue LED remains lighting as long as the transmitter has power; the blue LED flashing means the battery need to be replaced immediately.

### 5. Mute

Move the switch in the direction of the arrow to mute the microphone

### 6. Light touch power switch

Tap to turn on, long press (2 seconds) to turn off.

### 7. Antenna

1/4 wave length wire type antenna, it should be fully extended during normal operations

### 8. IR infrared port

Receiver infrared beam to synchronize frequencies, hold the transmitter with its IR port facing direct to receiver's IR port in a distance between 5-20cm.

### 9. Battery compartment

Insert a standard AA alkaline battery here, make sure to put the battery in the right polar directions.

### 10. Battery cover

Pull back gently on this cover at the ribbing and pry upwards to remove

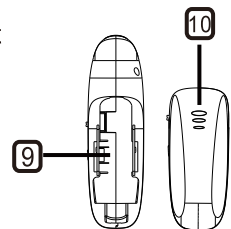
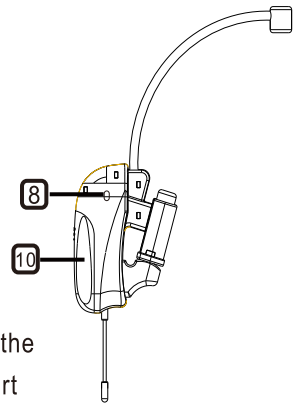
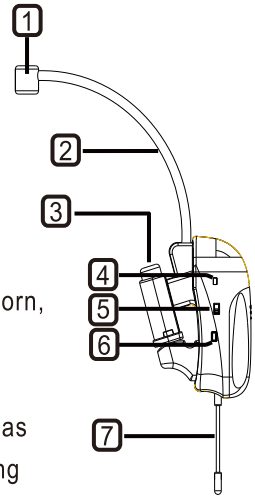



# System Setup

1. Connect the power supply to the rear of the receiver or put 2 pcs 1.5V AA battery and turn on the receiver.

## 2. Standard Display

The standard display shows the preselected group, channel

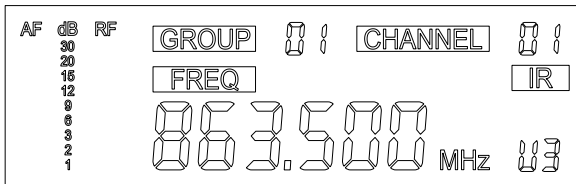

### Group

Tap the SET button, the GROUP blink, Push the up and down buttons to set the desired group (01-10), Press SET again to confirm. The display will return to standard after a short period of time of non-activity automatically.

**NOTE:** Each group 01-10 consists of 10 channels, each corresponding to a specific frequency. Some frequency bands, for specific regions, will not have 10 channels per group. (Groups vary by region.)

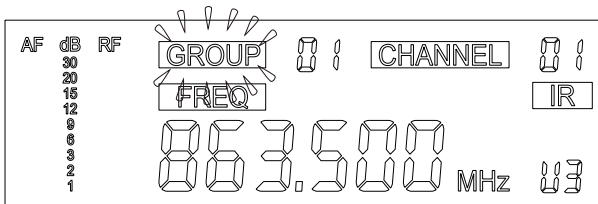

### Channel

After the step of setting group, press the SET again, the CHANNEL blink. Push the up and down buttons to set the desired channel (01-10), Press SET again to confirm. The display will return to standard after a short period of time of non-activity automatically.

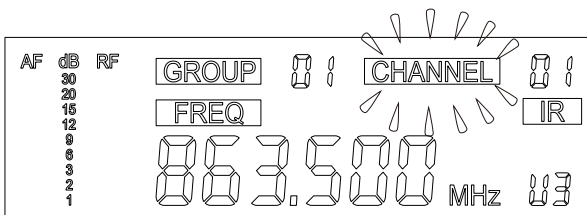

# System Setup

## IR Synch

After the step of setting channel, press the SET again, press the IR button, the receiver start to send the infrared signals (picture 2), then put the transmitter (handheld, body-pack or musical instrument) IR port close to the receiver's IR port, the transmitter has to be synchronized to the same frequency(group and channel) before using.

**NOTE:** The transmitter have be turned off and return-on while receiver send Infrared signals. After a successful sync, the display RF signal and ANT-A shows up (picture 3)

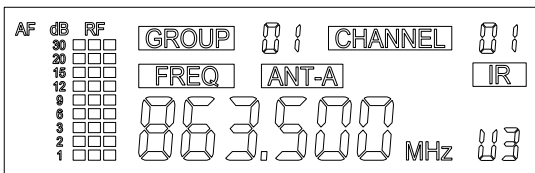
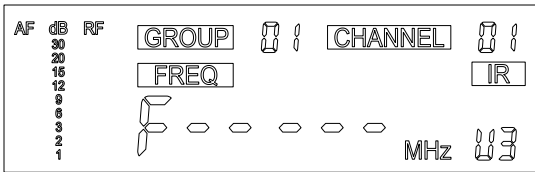

## Battery Life Level

The sign U0-U3 represents the level of battery life of receiver. U3 represent full battery life which the voltage is >2.7V, U2 represents the battery voltage is between 2.4V-2.7V; U1 represents the battery voltage is between 2.1V-2.4V; U0 represents the battery voltage is <2.1V; "U0" keeps flashing and the battery need to be replaced. When powered by DC adptor, the battery voltage remain showing "U3".

# Specifications

---

## Receiver

Frequency Preparation	PLL Synthesized Control
Frequency Range	600-952MHz (Region dependant)
Frequency Type	F3E
Modulation Type	FM
Channels:	100(10x10)
Oscillation System	VCO
Type of reception	Antenna Diversity
Receive Sensitivity	-110dBm (sinad $\geq$ 30dB)
Frequency Response	60Hz-17KHz+/-3dB
S/N Ratio	$\geq$ 105dB (-60dBm)
T.H.D	<0.5% at 1KHz
Dynamic Range	> 100dB
Operating Temperature	-10-+50°C
Display	Backlit LCD (63mm*22mm)
Audio Output	1*6.35mm Jack
Antenna:	2 pcs
Power Supply	DC9V/200mA
Dimensions( L*W*H):	100*130*35mm

# Specifications

---

## Body-pack Transmitter

Frequency Preparation	PLL Synthesized Control
Frequency Range	600-952MHz(Region dependant)
Frequency Deviation	±48KHz
Input	3 pin mini-XLR
RF Output Power	10mW
Controls	Power ON//OFF, Volume, SET frequency
Indicators	LED (PO), LCD(BATT, frequency)
Interface	Infrared
Antenna:	1/4 wave Length Wire Type
Power Supply	2*AA battery
Operating Voltage	3V
Operating time:	10h (depending on batteries)
Dimensions( L*W*H)	110*63*21mm

## Musical Instrument Transmitter

### Guitar Straight plug/Angled plug

Frequency Preparation	PLL Synthesized Control
Frequency Range	600-952MHz (Region dependant)
Frequency Deviation	±48KHz
RF Output Power	10mW
Controls	ON/OFF, Mute
Indicators	LED(PO/BATT)
Interface	Infrared
Antenna:	1/4 wave Length Wire Type
Power Supply	1*AA battery
Operating Voltage	1.2-1.5V
Operating time:	10h (depending on batteries)
Dimensions	120*54*28mm(straight plug) 90*71*28mm(angled plug)

# Specifications

---

## Saxophone/Horn Transmitter

<b>Frequency Preparation</b>	PLL Synthesized Control
<b>Frequency Range</b>	600-952MHz (Region dependant)
<b>Frequency Deviation</b>	±48KHz
<b>Microphone Type</b>	Condenser
<b>Polar pattern:</b>	Ultra-cardioid
<b>Cartridge size:</b>	Φ9.7*5.0mm
<b>Sensitivity:</b>	- 47dB±2dB
<b>RF Output Power</b>	10mW
<b>Controls</b>	ON/OFF, Mute
<b>Indicators</b>	LED(PO/BATT)
<b>Interface</b>	Infrared
<b>Antenna:</b>	1/4 wave Length Wire Type
<b>Power Supply</b>	1*AA battery
<b>Operating Voltage</b>	1.2-1.5V
<b>Operating time:</b>	10h (depending on batteries)
<b>Dimensions</b>	165*66*28mm



The specification won't do any further notice for the improvement

Actual product will not be as pictured